

JinkoSolar

Dual Glass Photovoltaic Module



Installation Manual

Solar
Jinko
Building Your Trust in Solar

Contents

1	General Information	1
1.1	Overview	1
1.2	Warnings	1
<hr/>		
2	Installation	4
2.1	Installation safety	4
2.2	Installation Condition	5
2.2.1	Climate condition	5
2.2.2	Site selection	5
2.2.3	Tilt angle selection	6
2.3	Mechanical Installation introduction	7
2.3.1	The installation of Dual Glass modules without frame	7
2.3.2	The installation of Dual Glass modules with frame	12
<hr/>		
3	Wiring and connection	18
<hr/>		
4	Maintenance and care	19
4.1	Visual Inspection	19
4.2	Cleaning	19
4.3	Inspection of Connector and Cable	20
<hr/>		
5	Electrical specification	20
<hr/>		
6	Disclaimer of Liability	20
<hr/>		
	Appendix: Applicable Products	22
<hr/>		

1. General Information

1.1 Overview

Thanks for choosing Jinko Solar PV modules. In order to ensure the PV modules are installed correctly, please read the following installation instructions carefully before modules are installed and used.

Please remember that these products generate electricity and certain safety measures need to be taken to avoid danger.

Make sure the module array is designed in such a way not to exceed the maximum system voltage of any system component such as connectors or inverters.

The assembly is to be mounted over a fire resistant roof covering rated for the application. Before mounting the module, please consult your local building department to determine approved roofing materials.

The modules are qualified for application class A: Hazardous voltage (IEC 61730: higher than 50V DC; EN 61730: higher than 120V), hazardous power applications (higher than 240W) where general contact access is anticipated. Modules qualified for safety through EN IEC 61730-1 and -2 within this application class are considered to meet the requirements for Safety Class II.

1.2 Warnings



- PV modules generate DC electrical energy when exposed to sunlight or other light sources. Active parts of module such as terminals can result in burns, sparks, and lethal shock.
- Artificially concentrated sunlight shall not be directed on the module or panel.
- Front protective glass is utilized on the module. Broken solar module glass is an electrical safety hazard (may cause electric shock or fire). These modules cannot be repaired and should be replaced immediately.
- To reduce the risk of electrical shocks or burns, modules may be covered with an opaque material during installation to avoid injury.
- The installation work of the PV array can only be done under the protection of sun-sheltering covers or sunshades and only qualified person can install or perform maintenance work on this module.
- Follow the battery manufacture's recommendations if batteries are used with modules.



- Do not use this module to replace or partly replace roofs and walls of living buildings.
- Do not install modules where flammable gas may be present.
- Do not touch live terminals with bare hands. Use insulated tools for electrical connections.
- Do not use water to extinguish the fire when the power supply is not disconnected.

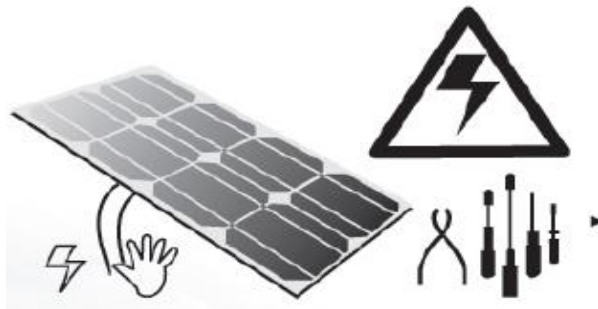

Use insulated tools for electrical connection

- Do not remove any part installed by Jinko Solar or disassemble the module.
- All instructions should be read and understood before attempting to install, wire, operate and maintain the module.
- Don't lift up PV modules using the attached cables or the junction box.
- All Dual glass PV systems except the non-metallic frame must be earthed. If there is no special regulation, please follow the National Electrical Code or other national code.
- Under normal conditions, a photovoltaic module is likely to experience conditions that produce more current and/or voltage than reported at standard test conditions. Accordingly, the value of I_{sc} and V_{oc} marked on the module should be multiplied by 1.25 when determining PV system component voltage ratings, conductor current ratings, fuse sizes, and size of controls connected to the PV output.
- Once the PV module has been shipped to the installation site, all of the parts should be unpacked properly with care.



- Do not stand or step on the PV module like below pictures show. This is prohibited and there is a risk of damage to the module and cause injury for you.
- Only PV modules with the same cell size should be connected in series.
- During transporting modules, please attempt to minimize shock or vibration to the module, as this may damage the module or lead to cell micro cracks.

- During all transportation situations, never drop the module from a vehicle, house or hands. This will damage module.
- Modules (glass, junction boxes, connectors, etc.) shall be protected from long-term exposure to environments containing sulfur, strong acid, strong alkaline, etc., which may pose a risk of corrosion to the product.
- Do not clean the glass with chemicals. Only use tap water. Make sure the module surface temperature is cool to the touch. Cleaning modules with cool water when module surface temp is high may result in glass breakage. Do not brush paint or corrosive substances on the surface of the modules.
- Do not disconnect any of the modules when under load.
- When looking at PV modules with anti-reflection (AR) coating technology, it will be normal to see some cells with a slight color difference at different angles. Modules with LRF(light reflective film) and without LRF should not be built in the same array or roof.
- The junction box connector should not be in contact with oily substances, organic solvents and other corrosive materials to avoid damage to the connector. For example, alcohol, gasoline, lubricants, rust inhibitors, herbicides and so on.
- Before the installation of modules, it is recommended to add rainproof facilities in the project site to avoid direct open-air placement.
- Corner protection of DV module is used to protect the module during transportation, and the customer can remove or leave it on modules.
- Connector of junction box can not be contacted with oily substances, for example, lubricant, rust inhibitor etc.
- The maximum altitude the PV module is designed for $\leq 2000\text{m}$.
- Meaning of crossed –out wheeled dustbin:

Do not dispose of electrical appliances as unsorted municipal waste, use separate collection facilities.

Contact your local government for information regarding the collection systems available.

If electrical appliances are disposed of in landfills or dumps, hazardous substances can leak into the groundwater and get into the food chain, damaging your health and well-being.

When replacing old appliances with new ones, the retailer is legally obligated to take back your old appliance for disposals at least free of charge.



2. Installation

2.1 Installation Safety

- Always wear protective head gear, insulating gloves and safety shoes (with rubber soles) and other protective measures during installation.
- When installing or maintaining the photovoltaic system, please do not wear metal rings, watches and other metal products, so as not to cause electric shock danger and damage the modules.
- Keep the PV module packed in the carton until installation. Once the modules are removed from the packing box, they should be installed and connected to the bus box in time. If they are not installed immediately, protective measures (such as adding rubber joint cover, etc.) should be taken on the connection head.
- Do not touch the PV module unnecessarily during installation. The glass surface and the frame may be hot. There is a risk of burns and electric shock.
- Do not work in rain, snow or windy conditions.
- Due to the risk of electrical shock, do not perform any work if the terminals of the PV module are wet.
- Use insulated tools and do not use wet tools.
- When installing PV modules, do not drop any objects (e.g., PV modules or tools).
- Make sure flammable gasses are not generated or present near the installation site.
- Insert module connectors fully and correctly. An audible "click" sound should be heard. This sounds confirms the connectors are fully seated. Check all connections.
- The module leads should be securely fastened to the module frame, Wire Management should be done in a way to avoid the connector from scratching or impacting the rear cover of the module.
- Do not touch the junction box and the end of the interconnect cables (connectors) with bare hands during installation or under sunlight, regardless if the PV module is connected to or disconnected from the system.
- Do not expose the PV module to excessive loads on the surface of the PV module or twist the frame.
- Do not hit or put excessive load on the glass or rear cover, this may break the cells or cause micro cracks.
- During the installation or operation, don't use sharp tools to wipe the rear cover and glass. Scratches can appear on the module.
- Do not drill holes in the frame. It may cause corrosion of the frame.

- When installing modules on roof mounted structures, please try to follow the “from top to bottom” and/or “from left to right” principle, and don’t step on the module. This will damage the module and would be dangerous for personal safety.
- Modules will have thermal expansion and cold contraction effect. When installing, the interval between two adjacent conventional modules is recommended > 10mm. The minimum clearance between two adjacent double-sided modules is recommended > 20mm; If there are special requirements, please confirm with Jinko and install it;
- During the installation, disassembly, maintenance and any other related processes of the product, it is recommended that the force applied between the cable and the connector, the cable and the junction box be no more than 60N.

2.2 Installation Condition

2.2.1 Climate Condition

Please install the modules in the following conditions:

- 1) The environment temperature: with in $-40^{\circ}\text{C}(-40^{\circ}\text{F})$ to $85^{\circ}\text{C} (185^{\circ}\text{F})$.
- 2) Do not install modules in a place where there may be water immersion.

* Note: The mechanical load bearing (include wind and snow loads) of the module is based on the approved mounting methods. The professional system installer must be responsible for mechanical load calculation according to the system design.

2.2.2 Site Selection

In most applications, Jinko solar PV modules should be installed in a location where they will receive maximum sunlight throughout the year. In the Northern Hemisphere, the module should typically face south, and in the Southern Hemisphere, the modules should typically face north. Modules facing 30 degrees away from true South (or North) will lose approximately 10 to 15 percent of their power output. If the module faces 60 degrees away from true South (or North), the power loss will be 20 to 30 percent.

When choosing a site, avoid trees, buildings or obstructions, which could cast shadows on the solar photovoltaic modules especially during the winter months when the arc of the sun is lowest over the horizon. Shading causes loss of output, even though the factory fitted bypass diodes of the PV module will minimize any such loss.

Do not install the PV module near open flame or flammable materials.

When solar modules are used to charge batteries, the battery must be installed in a manner, which will protect the performance of the system and the safety of its users. Follow the battery

manufacturer's guidelines concerning installation, operation and maintenance recommendations. In general, the battery (or battery bank) should be away from the main flow of people and animal traffic. Select a battery site that is protected from sunlight, rain, snow, debris, and is well ventilated. Most batteries generate hydrogen gas when charging, which can be explosive. Do not light matches or create sparks near the battery bank. When a battery is installed outdoors, it should be placed in an insulated and ventilated battery case specifically designed for the purpose.

Do not install the PV module in a location where it would be immersed in water or continually exposed to water from a sprinkler or fountain etc.

The PV module can be installed at a distance of 50 m to 500m from the seashore. However, when installing module within the distance, protect the connectors or add dust plugs. After removing the dust plugs, connect the connectors immediately and take other anti-rust measures to prevent rust.

When the modules are installed on the roof, they must be separated from the roof by more than 10cm to facilitate air circulation and heat dissipation.

2.2.3 Tilt Angle Selection

The tilt angle of the PV module is measured between the surface of the PV module and a horizontal ground surface (Figure 1). The PV module generates maximum output power when it faces the sun directly.

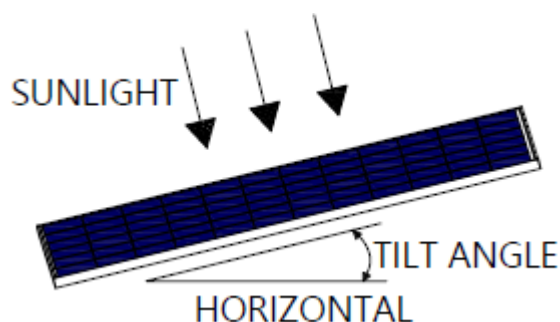

Figure1: PV module tilt angle

For standalone systems with batteries where the PV modules are attached to a permanent structure, the tilt angle of the PV modules should be selected to optimize the performance based on seasonal load and sunlight. In general, if the PV output is adequate when irradiance is low (e.g., winter), then the angle chosen should be adequate during the rest of the year. For grid-connected installations where the PV modules are attached to a permanent structure, PV modules should be tilted so that the energy production from the PV modules will be maximized on an annual basis.

2.3 Mechanical Installation Introduction

Jinko Frameless Dual glass modules usually can be mounted by the clamps.

Jinko Dual glass modules of frame usually can be mounted by the clamps and bolts.

According to IEC61215 for a maximum positive design loading of below 3600Pa, and negative design loading 1600Pa, with 1.5 times safety factor.

2.3.1 The Installation of Dual Glass Modules without Frame

Following components are just used in manual Jinko Dual glass module.		
clamp	Example	Description
End clamp		Connect the last module of each PV row
Middle clamp		Connect two modules

Table 1: Jinko Dual glass modules without frame mounted clamps

Be sure to avoid shadowing effects from the module clamps. When choosing this type of clamp-mounting method, please be sure to use at least six clamps on each modules, and three clamps should be attached on each long side of the module. Depending on the local wind and snow loads, if excessive pressure load is expected, additional clamps or support would be required to ensure the module can bear the load. The applied torque should be large enough to fix it steadily (about 16-20 N•m) .For safety, you'd better follow the clamps manufacture's recommendation. Please find detailed mounting information in the below illustration, and we suggest the clamps are mounted between J and K, as shown below.

Type1	Group 1~8	
Mechanical design load pressure	Length	Manual direction
Front surface: ≤ 1600 Pa Back surface: ≤ 1600 Pa	120mm	
Front surface: ≤ 3600 Pa Back surface: ≤ 1600 Pa	200mm	
Type2	Group 9~12	
Front surface: ≤ 1600 Pa Back surface: ≤ 1600 Pa	200mm	
Front surface: ≤ 3600 Pa Back surface: ≤ 1600 Pa	250mm	 <p data-bbox="694 1899 1396 1977">The middle of clamp should be between J and K, J=300mm, K=400mm, L=1/2 module length</p>

Type3	Group 13~31	
<p>Front surface: ≤3600 Pa Back surface: ≤1600 Pa</p>	<p>250mm</p>	 <ol style="list-style-type: none"> 1. Group 13~18 The middle of clamp should be between J and K, J=430mm,K=530mm 2. Group 19~20 The middle of clamp should be between J and K, J=A/4-50, K=A/4+50 3. Group 21~22 The middle of clamp should be between J and K, J=450,K=550 4. Group 23-31 The middle of clamp should be between J and K, J=A/5, K=A/4 <p>Note: A=module length</p>

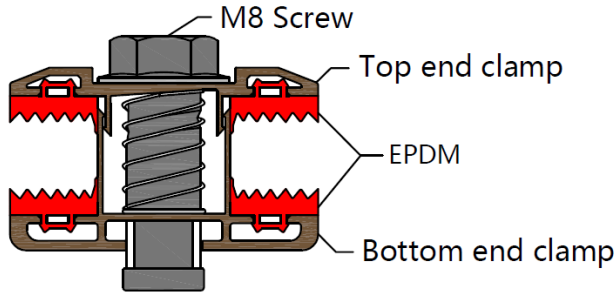
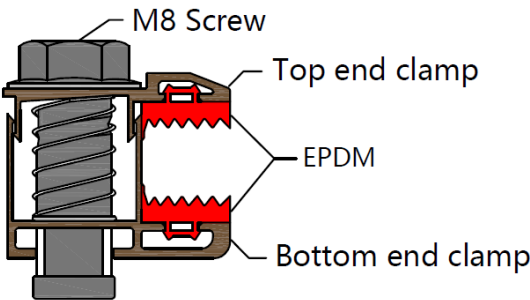
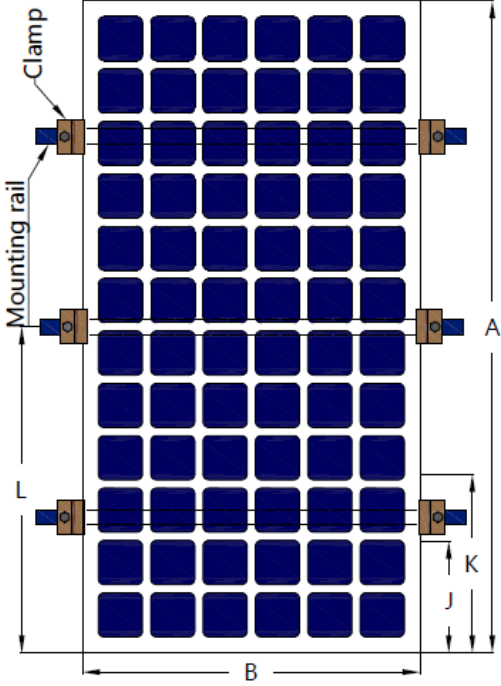
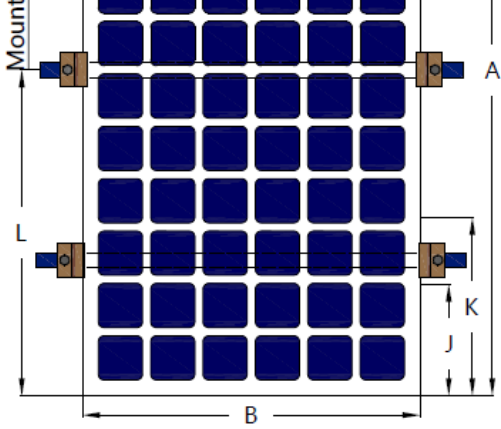
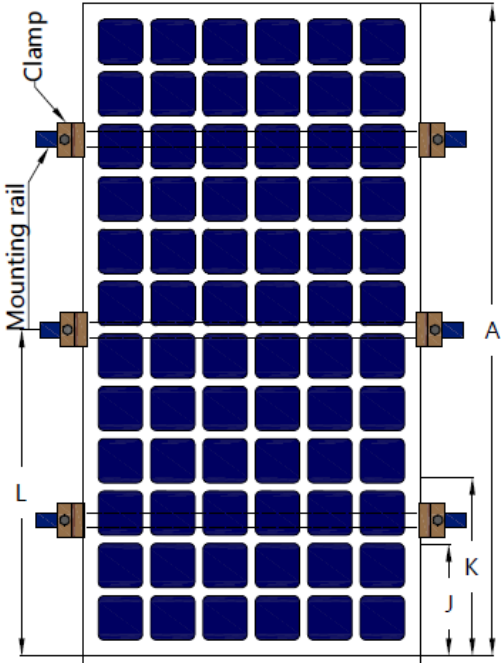
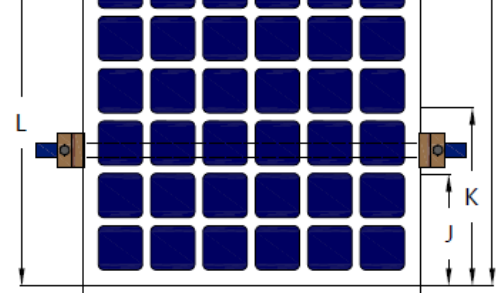
Table 2: The mounting method of clamps for Dual glass modules without frame

Module type	Dimensions (mm)		
	Maximum designed mechanical load : 3600Pa (positive) & 1600Pa (negative)		
	A*B	J	K
Group 1 & Group 5	1968*992	300	400
Group 2 & Group 6	1658*992	300	400
Group 3 & Group 7	1658*992	300	400

Group 4 & Group 8	1658*992	300	400
Group 9	1978*992 & 1978*986 2002*1002 & 2016*1012	300	400
Group 10	2000*992 & 1994*986 2024*1002 & 2047*1012	300	400
Group 11	1668*992 & 1650*986 1680*1002 & 1693*1012	300	400
Group 12	1698*998 & 1680*992 1698*1002 & 1721*1012	300	400
Group 13	2123*995 & 2132*1002	430	530
Group 14	1816*1002	430	530
Group 15	2187*1002	430	530
Group 16	1862*998	430	530
Group 17	2187*1028 & 2198*1026	430	530
Group 18	1862*1028 & 1872*1026	430	530
Group 19	2223*1025 2255*1032	450	550
Group 20	1889*1025	400	500
Group 21	2090*1039 & 2090*1038	L/4-50	L/4+50
Group 22	1750*1039 & 1750*1038	300	400
Group 23 & Group 24	1701*1122 & 1717*1132 1719*1134 & 1669*1122, 1685*1132 & 1678*1134	A/5 A=module length	A/4 A=module length
Group 25 & Group 26	1884*1122 & 1901*1132 1904*1134 & 1868*1134 1865*1132 & 1848*1122	A/5 A=module length	A/4 A=module length
Group 27 & Group 28	2027*1122 & 2046*1132 2049*1134 & 2089*1134 2086*1132 & 2067*1122	A/5 A=module length	A/4 A=module length
Group 29 & Group 30	2250*1122 & 2260*1130 2271*1132 & 2274*1134 2209*1130 & 2206*1122 2227*1132 & 2230*1134	A/5 A=module length	A/4 A=module length
Group 31	2385*1122 & 2393*1130 2408*1132 & 2411*1134	A/5 A=module length	A/4 A=module length

Table 3: Mechanical dimensions when modules installed with clamps fitting method

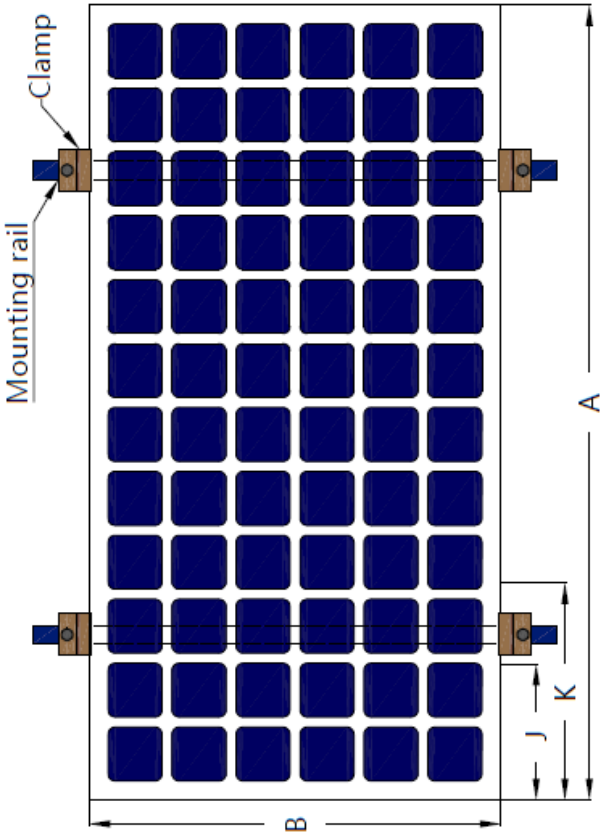
Before the installation, please read the operation instructions of the PV system carefully. In addition, please completely prepare the site before the installation.

Step 1:Install the rail	Graphical representation
Install the rail	
Step 2:Install the clamp	Graphical representation
Put the clamp into the rails	
Step 3:Install the module	Graphical representation
Put the module into the clamp and tighten the screw (about 16-20N•m)	

Table 4: The Schematic Diagram of the installation process of clamps

2.3.2 The Installation of Dual Glass Modules with Frame.

2.3.2.1 Fixation with Bolts (eight mounting holes)

The frame of each module has 8 mounting holes (Length* Width: 14mm*9mm) used to secure the modules to support structure. Always use all the eight mounting holes to secure the modules. The module frame must be attached to a mounting rail using M8 corrosion-proof bolts together with spring washers and flat washers in eight symmetrical locations on the PV module. The applied torque value should be big enough to fix the modules steadily. The reference value for M8 bolt is 16~20N*m. As to special support system or special installation requirement, please reconfirm with the support's supplier for the torque value. Please find detailed mounting information in the below illustration as Figure 2 and Table 5.

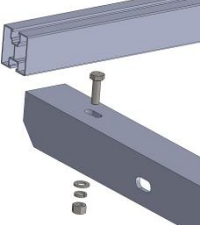
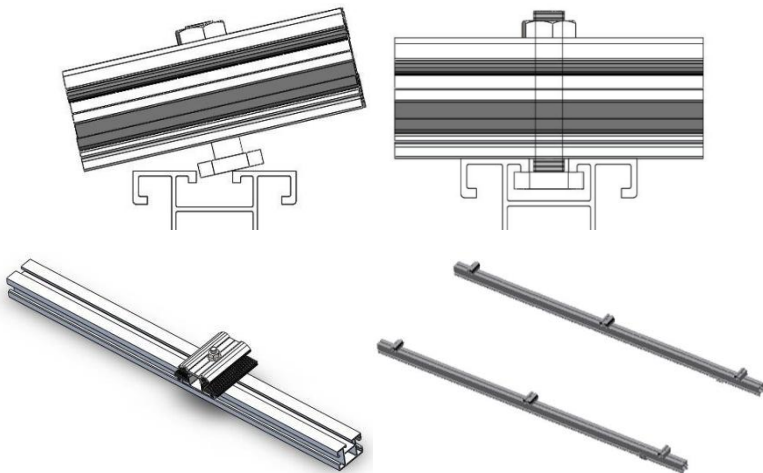
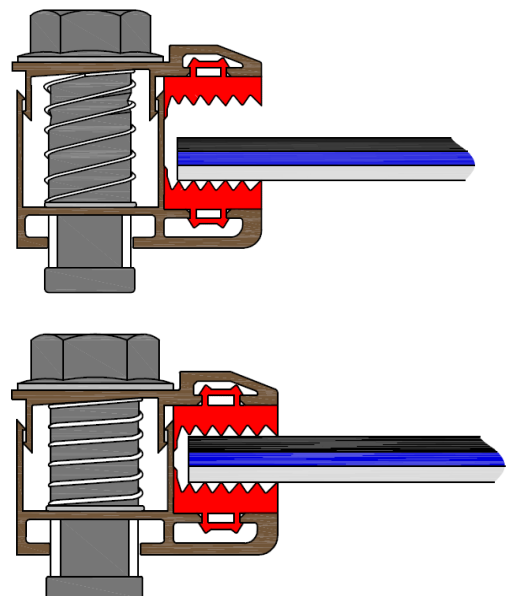
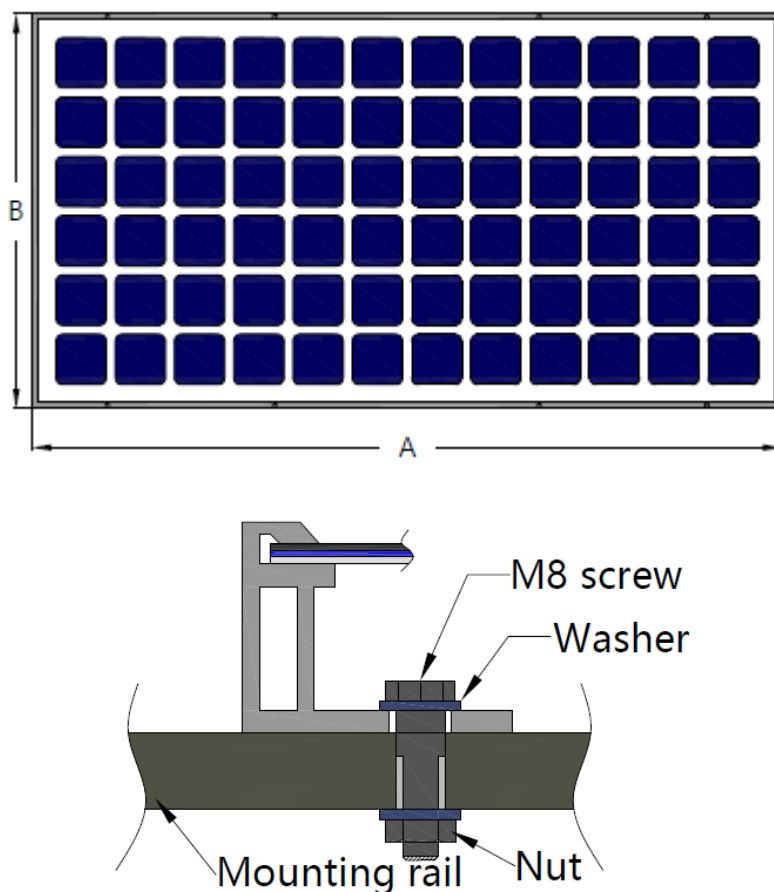

Figure 2: The mounting method of bolts for Dual glass modules with frame

Module type	Dimensions (mm)	
	Maximum designed mechanical load : 3600Pa (positive) & 1600Pa (negative)	
	Frame	A*B
Group 1	40	1984*998 & 1984*992 2009*1008 & 2023*1018
Group 2 & Group 7	40	2000*992 & 2031*1008 & 2054*1018
Group 3	35	1674*998 & 1686*1008 1699*1018 & 1656*992
Group 4 & Group 8	35	1698*998 & 1680*992 1704*1008 & 1727*1018
Group 5	40	1974*998
Group 6	35	1664*998
Group 19 & Group 20	30	1701*1122 & 1717*1132 1719*1134 & 1669*1122 1685*1132 & 1678*1134
Group 21 & Group 22	30	1884*1122 & 1901*1132 1904*1134 & 1868*1134 1865*1132 & 1848*1122
Group 23 & Group 24	30	2027*1122 & 2046*1132 2049*1134 & 2089*1134 2086*1132 & 2067*1122
Group 25 & Group 26	30	2274*1134 & 2278*1134 & 2230*1134
Group 27	30	2385*1122 & 2393*1130 2408*1132 & 2411*1134
Group 28	30&35	2465*1134

Table 5: Mechanical dimensions when modules installed with bolts fitting method

2.3.2.2 Mounting with Bolts (four mounting holes)

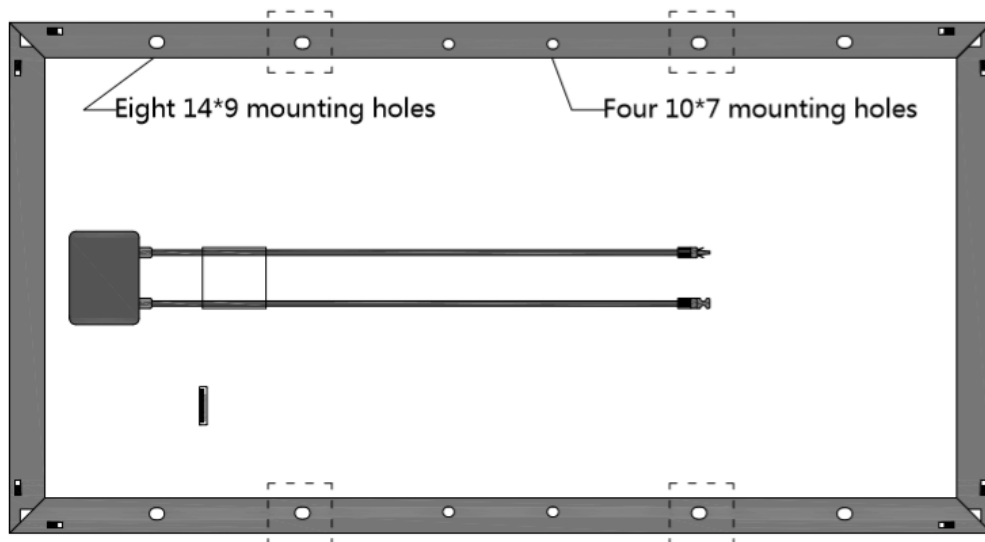

Figure 3: PV module installed with bolt fitting method (four mounting holes)

Module type	Dimensions (mm)	
	Maximum designed mechanical load : 3600Pa (positive) & 1600Pa (negative)	
	Frame	A*B
Group 13	30	2223*1025 & 2255*1032
Group 25	30	2274*1134 & 2278*1134
Group 26	30	2230x1134
Group 28	30&35	2465x1134

Table 6: Mechanical dimensions when modules installed with bolts fitting method

Note: The installation method of bolt fitting is based on the experimental results in Jinko.

2.3.2.3 Fixation with clamps at long sides of frames

The module clamps should not come into contact with the front glass and must not deform the frame. Be sure to avoid shadowing effects from the module clamps. The module frame is not to be modified under any circumstances. When choosing this type of clamp-mounting method, please be sure to use at least four clamps on each module, two clamps should be attached on each long sides of the module. Depending on the local wind and snow loads, if excessive pressure load is expected, additional clamps or support would be required to ensure the module can bear the load. The applied torque value should be big enough to fix the modules steadily (Please consult with the clamp or support's supplier for the specific torque value). Please find detailed mounting information in the below illustration, the mounting place distance is suggested bigger than J and less than K, as shown below.

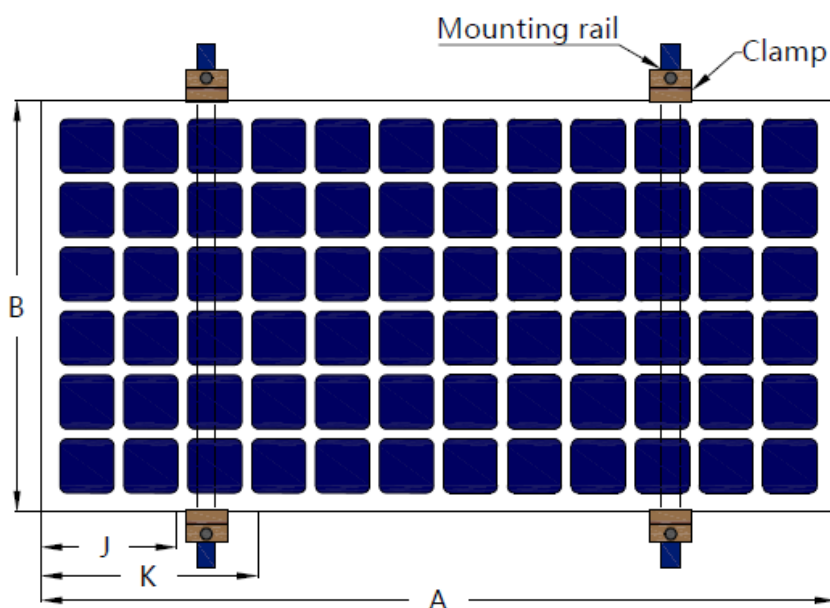

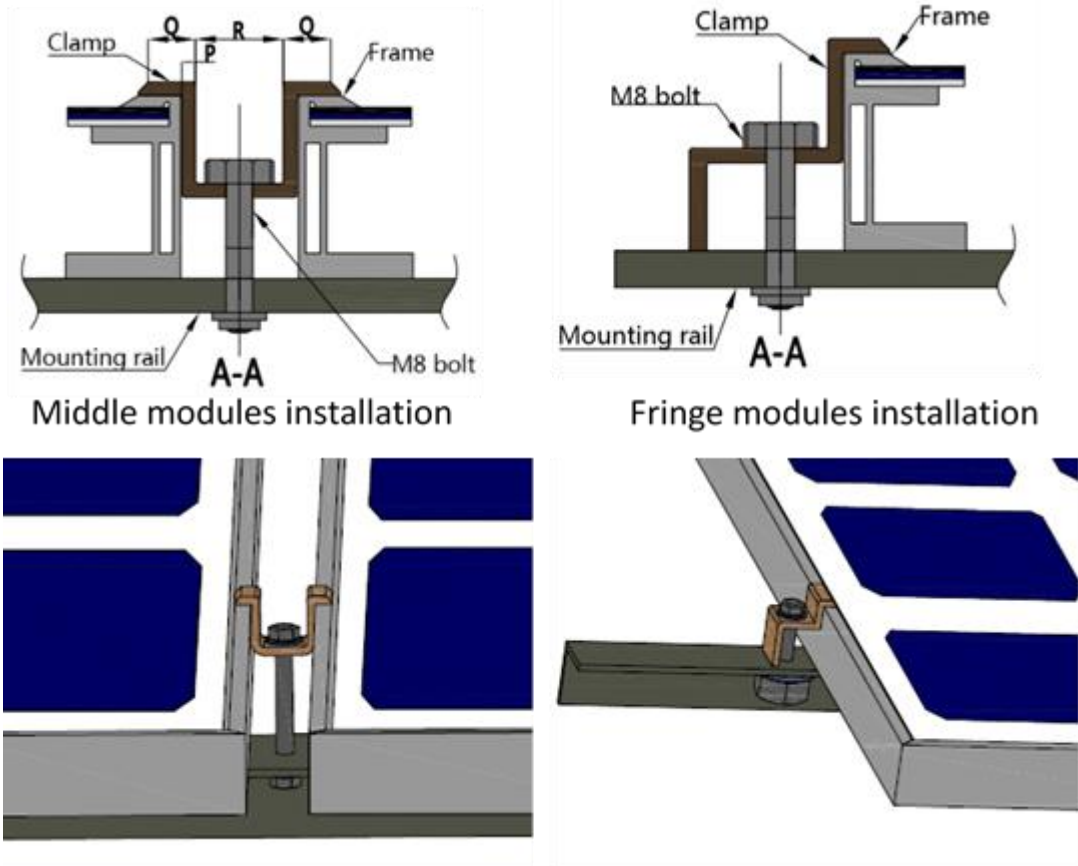

Figure 4: The mounting method of clamps for Dual glass modules with frame

Module type	Dimensions (mm)			
	Maximum designed mechanical load : 3600Pa (positive) & 1600Pa (negative)			
	Frame	A*B	J	K
Group 1	40	1984*998 & 1984*992 2009*1008 & 2023*1018	350	480
Group 2 & Group 7	40	2000*992	280	480
		2031*1008 & 2054*1018	350	480
Group 3	35	1674*998 & 1686*1008 1699*1018 & 1656*992	280	420
Group 4 & Group 8	35	1698*998 & 1680*992 1704*1008 & 1727*1018	280	420
Group 5	40 & 35	1974*998	280	480
Group 6	40 & 35	1664*998	280	420
Group 19 & Group 20	30	1701*1122 & 1717*1132 1719*1134 & 1669*1122 1685*1132 & 1678*1134	A/4±50 A=module length	A/4±50 A=module length
Group 21 & Group 22	30	1884*1122 & 1901*1132 1904*1134 & 1868*1134 1865*1132 & 1848*1122	A/4±50 A=module	A/4±50 A=module

			length	length
Group 23 & Group 24	30	2027*1122 & 2046*1132 2049*1134 & 2089*1134 2086*1132 & 2067*1122	A/4±50 A=module length	A/4±50 A=module length
Group 25 & Group 26	30	2274*1134 & 2278*1134 & 2230*1134	A/4±50 A=module length	A/4±50 A=module length
Group 27	30	2385*1122 & 2393*1130 2408*1132 & 2411*1134	A/4±50 A=module length	A/4±50 A=module length
Group 28	30&35	2465*1134	A/4±50 A=module length	A/4±50 A=module length

Table 7: Mechanical dimensions when modules installed with clamps fitting method

*** Note:**

- 1) All installation methods herein are only for reference, and Jinko solar will not provide related mounting components, the system installer or trained professional personnel must be responsible for the PV system's design, installation, and mechanical load calculation and security of the system.
- 2) Before installation, the following items should be addressed:
 - a) Visually check the module for any damage. Clean the module if any dirt or residue remains from shipping.
 - b) Check if module serial number stickers match.
- 3) Jinko modules are designed to meet a maximum positive (or downward) pressure of 3600Pa(Only refer to the mentioned module type in this manual) and negative (or upward)pressure of 1600Pa. This design load was then tested with a safety factor of 1.5 times. So Jinko modules are tested under a maximum downward pressure of 5400Pa and upward pressure of 2400Pa.When mounting modules in snow-prone or high-wind environments, special care should be taken to mount the modules in a manner that provides sufficient design strength while meeting local code requirements.
- 4) When installing the Dual glass modules at a certain angle, please installed the modules in front of the sun. But the back which the surface mounting the junction box is not allowed to exposed to the sun.

2.3.2.4 Fixation with clamps at long sides of frames (Long sides with C, short sides without C)

When installing modules using clamps on the long side of the frame, the mounting place distance of middle of clamp is suggested bigger than J and less than K. the length of clamp is 40mm. The

applicable product types and installation locations are shown in figure 4 and table 8, the following types have the same section design.

Module type	Dimensions (mm)			
	Maximum designed mechanical load : 3600Pa (positive) & 1600Pa (negative)			
	Frame	A*B	J	K
Group 2 & Group 7	30	2031*1008	400	500
Group 4 & Group 8	30	1704*1008	400	500
Group 9	30	2194*1008	400	500
Group 10	30	1868*1004	400	500
Group 11	30	2194*1034 & 2205*1032	410	520
Group 12	30	1868*1034 & 1878*1032	400	500
Group 13	30	2223*1025 & 2255*1032	450	550
Group 14	30	1889*1025	400	500
Group 15	30	2090*1039 & 2090*1038 2096*1039	1/4L±50	1/4L±50
Group 16	30	1750*1039 & 1750*1038	1/4L±50	1/4L±50
Group 17	30	2018*1008	400	500
Group 18	35	1692*1008	400	500
Group 25 & Group 26	30	2274×1134 & 2278*1134 & 2230*1134	1/4L±50	1/4L±50
Group 28	30&35	2465×1134	1/4L±50	1/4L±50

Table8: Mechanical dimensions when modules installed at long side Clamp fitting method

2.3.2.5 Mounting with Bolts (NEXTracker four mounting holes)

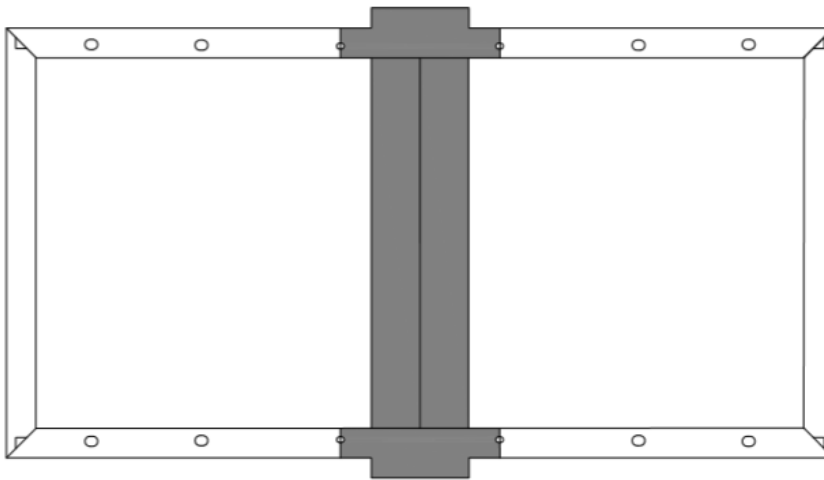

Figure 5: PV module installed with bolt fitting method (NEXTracker)

Module type	Frame	A*B (mm)	Maximum designed mechanical load and Method of installation (400mm)
JKMxxxM-72HL4-BDVP	30	2274x1134 & 2278*1134	+1600/-1600*
JKMxxxM-7RL3-BDVP	30	2205*1032	+1400/-1400*
JKMxxxN-78HL4-BDV	30&35	2465x1134	+1600/-1600*

Table9: Mechanical dimensions for bolt fitting method (NEXTracker)

Note: The installation method of bolt fitting (NEXTracker) is based on the experimental results in Jinko.

The design of the NexTracker tracking bracket, the selection of accessories and the installation of modules should be completed by a professional system installer, which can refer to Jinko's mechanical load.

The load described in this manual is the design load. When calculating the maximum test load, 1.5 times of safety factor should be considered.

If the design load is greater than 1067Pa (1600Pa test load), consult the support supplier.

* For details, consult with component suppliers and support suppliers.

3. Wiring and connection

- a) Before this procedure, please read the operation instructions of the PV system carefully. Make wiring by Multi-connecting cables between the PV modules in series or parallel connection, which is determined by user's configuration requirement for system power, current and voltage.
- b) PV module connected in series should have similar current. Modules must not be connected together to create a voltage higher than the permitted system voltage(1500VDC). The maximum number of modules in series depends on system design, the type of inverter used and environmental conditions.
- c) The maximum fuse rating value in an array string can be found on the product label or in the product datasheet. The fuse rating value is also corresponding to the maximum reverse current that a module can withstand. Thus based on the maximum series fuse rating of module and local electrical installation criteria, make sure the modules strings in parallel for connection need to be assembled with appropriate string fuse for circuit protection.
- d) Open the combiner box of the control system and connect the conductor from the PV arrays to the combiner box in accordance with the the design and local codes and standards. The cross-sectional area and cable connector capacity must satisfy the maximum short-circuit of the PV system (for a single component, we recommended that the cross-sectional area of cables be 4mm² and the rated current of connectors be more than 10A), otherwise cables and connectors will become overheating for large current. Please pay attention to the

temperature limit of cables is 85°C.

- e) Follow the requirements of applicable local and national electrical codes.
- f) These modules contain factory installed bypass diode .if these modules are incorrectly connected to each other, the bypass diodes, cable or junction box maybe damaged.
- g) If modules are connected in series, the total voltage is equal to the sum of individual voltages. The recommended as below,

$$\text{System voltage} \geq N * \text{Voc} [1 + \text{TCVoc} * (\text{Tmin} - 25)]$$

Where

N module numbers in series

Voc Open circuit voltage (refer to product label or data sheet)

TCVoc Temperature coefficient of open circuit voltage (refer to product label or data sheet)

Tmin Minimum ambient temperature

4. Maintenance and care

It is required to perform regular inspection and maintenance of the modules, especially during the warranty period. To ensure optimum module performance, Jinko recommends the following maintenance measures:

4.1 Visual Inspection

Inspect the modules visually to find if there are any visual defects, If there are, the following items should be evaluated:

- a) If modules are observed having slight cell color differences at different angles, this is a normal phenomenon of modules with anti-reflection coating technology.
- b) Whether the glass is broken;
- c) No sharp objects are in contact with the PV module surfaces
- d) PV modules are not shaded by unwanted obstacles and; or foreign material
- e) Corrosion along the cells' bus-bar. The corrosion is caused by moisture intrusion through the module rear cover. Check the rear cover for damage.
- f) Check whether the rear cover is burn out.
- g) Check if screws and mounting brackets are tight, adjust and tighten as necessary.

4.2 Cleaning

- a) A build up of dust or dirt on the module(s) front face will result in a decreased energy output. Clean the panel(s) preferably once per annum if possible (depend on site conditions) using

a soft cloth dry or damp, as necessary. Water with high mineral content may leave deposits on the glass surface and is not recommended. It is recommended to use neutral water to clean the glass to avoid strong acid and alkali, so as not to cause damage to the glass coating layer.

- b) Never use abrasive material under any circumstances.
- c) In order to reduce the potential for electrical and thermal shock, Jinko recommends cleaning PV modules during early morning or late afternoon hours when solar radiation is low and the modules are cooler, especially in regions with hotter temperatures.
- d) Never attempt to clean a PV module with broken glass or other signs of exposed wiring, as this presents a shock hazard.
- e) Never use chemicals when cleaning modules as this may affect the module warranty and energy output.

4.3 Inspection of Connector and Cable

It's recommended to implement the following preventive maintenance every 6 months:

- a) Check the sealing gels of the junction box for any damage.
- b) Examine the PV module(s) for signs of deterioration. Check all wiring for possible rodent damage, weathering and that all connections are tight and corrosion free. Check electrical leakage to ground. The Dual glass modules of the non-metallic frame should not be earthed.

5. Electrical specification

The module electrical ratings are measured under Standard Test Conditions, which are 1000W/m², irradiance with AM 1.5 spectrum and 25 deg (77°F) ambient temperature. The module might produce more or less voltage or current than rating value in uncertainty condition. Accordingly, the values of I_{sc} and V_{oc} marked on this module should be multiplied by a factor of 1.25 when determining component voltage ratings, conductor current ratings, fuse sizes, and size of controls connected to the PV output.

6. Disclaimer of Liability

Because the use of the manual and the conditions or methods of installation, operation, use and maintenance of photovoltaic (PV) product are beyond Jinko's control, Jinko does not accept any legal responsibility and expressly disclaims liability for any person and property damage arising from the failure to follow the installation, operation, use, maintenance provided in the manual,

and for any disputes caused by no-quality reasons.

Intellectual Property Right: No responsibility is assumed by Jinko for any infringement of intellectual property or other rights of third parties, which may result from use of the PV product. No license is granted by implication or otherwise under any intellectual property rights or related use authorization.

Jinko reserve the right to change the manual, the PV produce, the specifications or product information. Any information may be changed due to business needs, technical level or other objective environment, which is not representative of the negation for the original information.

The information in this manual is based on Jinko's knowledge and experience and is believed to be reliable, but such information and suggestions (without limitations), which is not the only and proprietary approach, do not constitute security and quality assurance, expresses or implied.

Appendix : Applicable Products

This document is applicable to the series of solar modules as listed below:

(1) Dual glass without frame series products:

Group 1

JKMxxxPP ^① -72-DV ^②	JKMS ^③ xxxPP-72-DV	JKMxxxPP-72-DV-J ^④	JKMSxxxPP-72-DV-J
JKMxxx PP-72H-DV			

(xxx=285-350, in steps of 5)

Group 2

JKMxxxPP-60-DV	JKMSxxxPP-60-DV	JKMxxxPP-60-DV-J	JKMSxxxPP-60-DV-J
JKMxxx PP-60H-DV			

(xxx=240-290, in steps of 5)

Group 3

JKMxxxPP-48-DV	JKMSxxxPP-48-DV	JKMxxxPP-48-DV-J	JKMSxxxPP-48-DV-J
----------------	-----------------	------------------	-------------------

(xxx=190-230, in steps of 5)

Group 4

JKMxxxPP-36-DV	JKMSxxxPP-36-DV	JKMxxxPP-36-DV-J	JKMSxxxPP-36-DV-J
----------------	-----------------	------------------	-------------------

(xxx=145-170, in steps of 5)

Group 5

JKMxxxM-72-DV	JKMSxxxM-72-DV	JKMxxxM-72-DV-J	JKMSxxxM-72-DV-J
JKMxxxM -72H-DV			

(xxx=250-420, in steps of 5)

Group 6

JKMxxxM-60-DV	JKMSxxxM-60-DV	JKMxxxM-60-DV-J	JKMSxxxM-60-DV-J
JKMxxxM-60H-DV			

(xxx=210-350, in steps of 5)

Group 7

JKMxxxM-48-DV	JKMSxxxM-48-DV	JKMxxxM-48-DV-J	JKMSxxxM-48-DV-J
---------------	----------------	-----------------	------------------

(xxx=170-250, in steps of 5)

Group 8

JKMxxxM-36-DV	JKMSxxxM-36-DV	JKMxxxM-36-DV-J	JKMSxxxM-36-DV-J
---------------	----------------	-----------------	------------------

(xxx=150-180, in steps of 5)

Group 9

JKMxxxM-72-BDV ^⑤			
-----------------------------	--	--	--

(xxx=300-420, in steps of 5)

JKMxxxM-72-BDVP			
-----------------	--	--	--

(xxx=315-430, in steps of 5)

Group 10

JKMxxxM-72H ^⑦ -BDV			
-------------------------------	--	--	--

(xxx=390-420, in steps of 5)

JKMxxxM-72H-BDVP			
------------------	--	--	--

(xxx=315-430, in steps of 5, 72 cells)

JKMxxxM-72H-MBB-BDVP			
----------------------	--	--	--

(xxx=375-435, in steps of 5)

JKMxxxN-72H-MBB-BDV			
---------------------	--	--	--

(xxx=375-445, in steps of 5)

Group 11

JKMxxxM-60-BDV			
----------------	--	--	--

(xxx=250-350, in steps of 5)

JKMxxxM-60-BDVP			
-----------------	--	--	--

(xxx=260-355, in steps of 5)

Group 12

JKMxxxM-60H-BDV			
-----------------	--	--	--

(xxx=250-350, in steps of 5)

JKMxxxM-60H-BDVP			
------------------	--	--	--

(xxx=260-355, in steps of 5)

JKMxxxM-60H-MBB-BDVP			
----------------------	--	--	--

(xxx=310-360, in steps of 5)

JKMxxxN-60H-MBB-BDV			
---------------------	--	--	--

(xxx=315-370, in steps of 5)

Group 13

JKSM3-DDCA-xxx	JKSN3-DDCA-xxx		
----------------	----------------	--	--

(xxx=400-450, in steps of 5)

Group 14

JKSM3-CDCA-xxx	JKSN3-CDCA-xxx		
----------------	----------------	--	--

(xxx=340-380, in steps of 5)

Group 15

JKMxxxM-78H-BDVP			
------------------	--	--	--

(xxx=405-470, in steps of 5)

JKMxxxN-78H-BDV			
-----------------	--	--	--

(xxx=410-470, in steps of 5)

Group 16

JKMxxxM-66H-BDVP			
------------------	--	--	--

(xxx=340-390, in steps of 5)

JKMxxxN-66H-BDV			
-----------------	--	--	--

(xxx=345-395, in steps of 5)

Group 17

JKMxxxM-7RL3-BDVP	JKMxxxM-7RL3-BDVP-J		
-------------------	---------------------	--	--

(xxx=420-490, in steps of 5)

JKMxxxN-7RL3-BDV			
------------------	--	--	--

(xxx=425-485, in steps of 5)

Group 18

JKMxxxM-6RL3-BDVP	JKMxxxM-6RL3- BDVP-J		
-------------------	----------------------	--	--

(xxx=355-410, in steps of 5)

JKMxxxN-6RL3-BDV			
------------------	--	--	--

(xxx=360-410, in steps of 5)

Group 19

JKMxxxM-78HL3-BDVP	JKMxxxM-78HL3-MBB-BDVP		
--------------------	------------------------	--	--

(xxx=430-485, in steps of 5)

Group 20

JKMxxxM-66HL3-BDVP	JKMxxxM-66HL3-MBB-BDVP		
--------------------	------------------------	--	--

(xxx=365-410, in steps of 5)

Group 21

JKMxxxM-72HLM-BDVP			
--------------------	--	--	--

(xxx=400-460, in steps of 5)

Group 22

JKMxxxM-60HLM-BDVP			
--------------------	--	--	--

(xxx=335-380, in steps of 5)

Group 23

JKMxxxM-54HL4-BDVP			
--------------------	--	--	--

(xxx=345-405, in steps of 5)

JKMxxxN-54HL4-BDV			
-------------------	--	--	--

(xxx=345-415, in steps of 5)

Group 24

JKMxxxM-5RL4-BDVP			
-------------------	--	--	--

(xxx=345-405, in steps of 5)

JKMxxxN-5RL4-BDV			
------------------	--	--	--

(xxx=350-415, in steps of 5)

Group 25

JKMxxxM-60HL4-BDVP			
--------------------	--	--	--

(xxx=385-450, in steps of 5)

JKMxxxN-60HL4-BDV			
-------------------	--	--	--

(xxx=385-465, in steps of 5)

Group 26

JKMxxxM-6TL4-BDVP			
-------------------	--	--	--

(xxx=385-450, in steps of 5)

JKMxxxN-6TL4-BDV			
------------------	--	--	--

(xxx=385-465, in steps of 5)

Group 27

JKMxxxM-66HL4-BDVP			
--------------------	--	--	--

(xxx=425-495, in steps of 5)

JKMxxxN-66HL4-BDV			
-------------------	--	--	--

(xxx=425-510, in steps of 5)

Group 28

JKMxxxM-6RL4-BDVP			
-------------------	--	--	--

(xxx=425-495, in steps of 5)

JKMxxxN-6RL4-BDV			
------------------	--	--	--

(xxx=425-510, in steps of 5)

Group 29

JKMxxxM-72HL4-BDVP			
--------------------	--	--	--

(xxx=460-540, in steps of 5)

JKMxxxN-72HL4-BDV			
-------------------	--	--	--

(xxx=460-555, in steps of 5)

Group 30

JKMxxxM-7TL4- BDVP	JKMxxxM -7TL4- BDVP -J		
--------------------	------------------------	--	--

(xxx=460-540, in steps of 5)

JKMxxxN-7TL4- BDV			
-------------------	--	--	--

(xxx=460-555, in steps of 5)

Group 31

JKMxxxM-7RL4- BDVP	JKMxxxM -7RL4- BDVP -J		
--------------------	------------------------	--	--

(xxx=490-585, in steps of 5)

JKMxxxN-7RL4- BDV			
-------------------	--	--	--

(xxx=500-605, in steps of 5)

(2) Dual glass with frame series products :

Group 1

JKMxxxM-72-BDV ⁵			
-----------------------------	--	--	--

(xxx=300-420, in steps of 5)

JKMxxxM-72-BDVP			
-----------------	--	--	--

(xxx=315-430, in steps of 5)

Group 2

JKMxxxM-72H ⁷ -BDV			
-------------------------------	--	--	--

(xxx=300-420, in steps of 5)

JKMxxxM-72H-BDVP			
------------------	--	--	--

(xxx=315-430, in steps of 5)

Group 3

JKMxxxM-60-BDV			
----------------	--	--	--

(xxx=250-350, in steps of 5)

JKMxxxM-60-BDVP			
-----------------	--	--	--

(xxx=260-355 in steps of 5)

Group 4

JKMxxxM-60H-BDV			
-----------------	--	--	--

(xxx=250-350, in steps of 5)

JKMxxxM-60H-BDVP			
------------------	--	--	--

(xxx=260-355, in steps of 5)

Group 5

JKMxxxM-72-DV-F®	JKMxxxPP-72-DV-F		
------------------	------------------	--	--

(xxx=285-350, in steps of 5)

Group 6

JKMxxxM-60-DV-F	JKMxxxPP-60-DV-F		
-----------------	------------------	--	--

(xxx=240-290, in steps of 5)

Group 7

JKMxxxM-72H-MBB-BDVP			
----------------------	--	--	--

(xxx=375-435, in steps of 5)

JKMxxxN-72H-MBB-BDV			
---------------------	--	--	--

(xxx=375-445, in steps of 5)

Group 8

JKMxxxM-60H-MBB-BDVP			
----------------------	--	--	--

(xxx=310-360, in steps of 5)

JKMxxxN-60H-MBB-BDV			
---------------------	--	--	--

(xxx=315-370, in steps of 5)

Group 9

JKMxxxM-78H-BDVP			
------------------	--	--	--

(xxx=405-470, in steps of 5)

JKMxxxN-78H-BDV			
-----------------	--	--	--

(xxx=410-470, in steps of 5)

Group 10

JKMxxxM-66H-BDVP			
------------------	--	--	--

(xxx=340-390, in steps of 5)

JKMxxxN-66H-BDV			
-----------------	--	--	--

(xxx=345-395, in steps of 5)

Group 11

JKMxxxM-7RL3-BDVP	JKMxxxM-7RL3-BDVP-J		
-------------------	---------------------	--	--

(xxx=420-490, in steps of 5)

JKMxxxN-7RL3-BDV			
------------------	--	--	--

(xxx=425-485, in steps of 5)

Group 12

JKMxxxM-6RL3-BDVP	JKMxxxM-6RL3- BDVP-J		
-------------------	----------------------	--	--

(xxx=355-410, in steps of 5)

JKMxxxN-6RL3-BDV			
------------------	--	--	--

(xxx=360-410, in steps of 5)

Group 13

JKMxxxM-78HL3-BDVP	JKMxxxM-78HL3-MBB-BDVP		
--------------------	------------------------	--	--

(xxx=430-485, in steps of 5)

Group 14

JKMxxxM-66HL3-BDVP	JKMxxxM-66HL3-MBB-BDVP		
--------------------	------------------------	--	--

(xxx=365-410, in steps of 5)

Group 15

JKMxxxM-72HLM-BDVP			
--------------------	--	--	--

(xxx=400-460, in steps of 5)

Group 16

JKMxxxM-60HLM-BDVP			
--------------------	--	--	--

(xxx=335-380, in steps of 5)

Group 17

JKMxxxM-72H-DV			
----------------	--	--	--

(xxx=250-420, in steps of 5)

Group 18

JKMxxxM-60H-DV			
----------------	--	--	--

(xxx=210-350, in steps of 5)

Group 19

JKMxxxM-54HL4-BDVP			
--------------------	--	--	--

(xxx=345-405, in steps of 5)

JKMxxxN-54HL4-BDV			
-------------------	--	--	--

(xxx=345-415, in steps of 5)

Group 20

JKMxxxM-5RL4-BDVP			
-------------------	--	--	--

(xxx=345-405, in steps of 5)

JKMxxxN-5RL4-BDV			
------------------	--	--	--

(xxx=350-415, in steps of 5)

Group 21

JKMxxxM-60HL4-BDVP			
--------------------	--	--	--

(xxx=385-450, in steps of 5)

JKMxxxN-60HL4-BDV			
-------------------	--	--	--

(xxx=385-465, in steps of 5)

Group 22

JKMxxxM-6TL4-BDVP			
-------------------	--	--	--

(xxx=385-450, in steps of 5)

JKMxxxN-6TL4-BDV			
------------------	--	--	--

(xxx=385-465, in steps of 5)

Group 23

JKMxxxM-66HL4-BDVP			
--------------------	--	--	--

(xxx=425-495, in steps of 5)

JKMxxxN-66HL4-BDV			
-------------------	--	--	--

(xxx=425-510, in steps of 5)

Group 24

JKMxxxM-6RL4-BDVP			
-------------------	--	--	--

(xxx=425-495, in steps of 5)

JKMxxxN-6RL4-BDV			
------------------	--	--	--

(xxx=425-510, in steps of 5)

Group 25

JKMxxxM-72HL4-BDVP			
--------------------	--	--	--

(xxx=460-550, in steps of 5)

JKMxxxN-72HL4-BDV			
-------------------	--	--	--

(xxx=460-570, in steps of 5)

Group 26

JKMxxxM-7TL4- BDVP	JKMxxxM -7TL4- BDVP -J		
--------------------	------------------------	--	--

(xxx=460-540, in steps of 5)

JKMxxxN-7TL4- BDV			
-------------------	--	--	--

(xxx=460-555, in steps of 5)

Group 27

JKMxxxM-7RL4- BDVP	JKMxxxM -7RL4- BDVP -J		
--------------------	------------------------	--	--

(xxx=490-585, in steps of 5)

JKMxxxN-7RL4- BDV			
-------------------	--	--	--

(xxx=500-605, in steps of 5)

Group 28

JKMxxxN-78HL4- BDV			
--------------------	--	--	--

(xxx=590-610, in steps of 5)

Notes:

- 1) PP: the eagle series module

- 2) DV: photovoltaic Module- Dual glass with 1500V
- 3) JKMS: the smart series module
- 4) J: customized product for Japanese market
- 5) BDV: the bifacial N type series module
- 6) BDVP: the bifacial P type series module
- 7) H:Half-cut series module
- 8) F: Normal Dual+frame series module
- 9) MBB: Nine busbar series module
- 10) RL3: 163.75 large cell TR series module
- 11) HL3: 163.75 large cell half-cut series module
- 12) HLM: 166 large cell TR series module
- 13) L4: 182 large cell series module

Jinko Module	Wafer type	Technology	Cell Number	Module Type	Cell	Junction Box
STC condition: JKS	p-type Mono: M	Full cell: 1	60: A	Normal mono-facial: A	158 5BB Mono-facial: A	Normal: A
BSTC condition: JKB	Poly: P	Half cell: 2	72: B	All black mono-facial: B	158 5BB Bi-facial: B	MX: B
	N-type Mono: N	TR: 3	66: C	Transparent back sheet: C	158 9BB Bi-facial: C	MX3: C
		Shingling: 4	78: D	Bifacial dual glass: D	161 9BB Bi-facial: D	EP: D

Note

Global Sales & Marketing Center

Jinko Building
#99 Shouyang Road, Jingan District,
Shanghai, China 200027
Tel: +86 21 5183 8777
Fax: +86 21 5180 8600

Jiangxi Manufacture Base

No.1 Jinko Road,
Shangrao Economic Development Zone,
Jiangxi Province, China 334100
Tel:+86 793 858 8188
Fax:+86 793 846 1152

Zhejiang Manufacture Base

No.58 Yuanxi Road,
Haining Yuanhua Industrial Park,
Zhejiang Province, China 314416
Tel: +86 573 8798 5678
Fax: +86 573 8787 1070